

Biometric Full Height Turnstile

Cloud CT835: Full Height Turnstile

Semi-automatic mechanism

Visible indicator

SUS304 stainless steel cabinet

Modular design



Application



Industrial facility



Corporate security



Government security



Public transportation

Specifications

Power requirements	AC110V/220V, 50/60Hz	
Working temperature	-28°C~60°C	
Working humidity	0%~95%	
Working environment	Indoor/Outdoor	
Speed of throughput	RFID	Maximum 30/minute
	Fingerprint	Maximum 25/minute
	Face	Maximum 15/minute
	Vein	Maximum 15/minute
Lane width(mm)	580	
Footprint(mm*mm)	1400*1395	
Dimension(mm)	L=1400 W=1395 H=2220	
Dimension with packing(mm)	1975x1085x935&2100x1435x735	
LED indicator	Y	
Cabinet material	SUS304 Stainless Steel	
Barrier material	SUS304 Stainless Steel	
Barrier movement	Rotating	
Emergency mode	Y	
Security level	High	
MCBF	2 million	
Ingress protection	IP54	

Dimensions (mm)

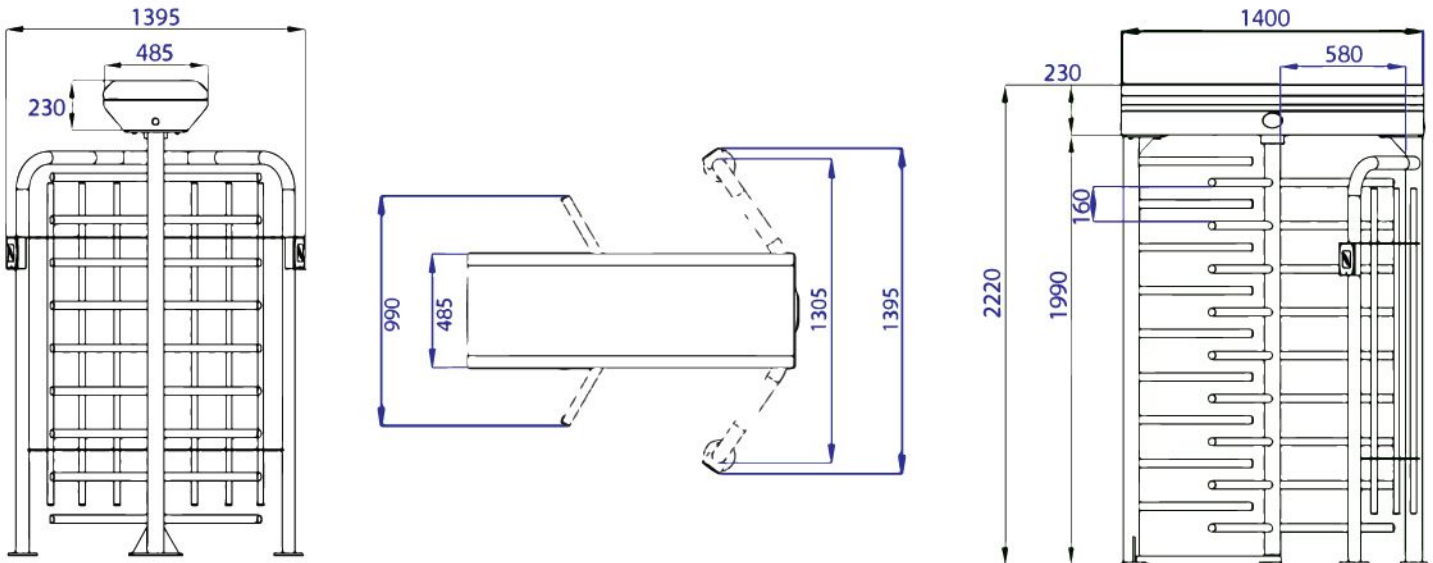

Authorized Distributor and Service Center

NEDO CORPORATION

KARACHI | LAHORE | ISLAMABAD

www.nedogroup.com
UAN: 021-111-633-675